

THIS DOCUMENT IS THE PROPERTY OF BOSTON WHALER, INC. MFG. DEPT., EDGEWATER, FLORIDA. ALL RIGHTS ARE RESERVED. THIS DOCUMENT AND INFORMATION CONTAINED MUST NOT BE COPIED OR DISCLOSED TO OTHERS WITHOUT WRITTEN PERMISSION OF BOSTON WHALER, INC.

DWG. NO:
09201

REV.
C

CURRENT ECD
050577

NOTES:

1. REF. DWG. 01201 FOR LIST OF ALL FIXTURES.
2. REF. DWG. 01251 FOR ALL HOSE CUT LENGTHS.
3. REF. DWG. 16109 FOR CONSOLE CUTOUT DETAILS.
4. REF. DWG. 05109 FOR LAM DETAILS.

REVISIONS					
REV.	DESCR.	BY	DATE	APPVD.	ECN NO.
A	MOVED #12 TO DWG.11201	JFH	10-17-05	VPK	050577
B	MOVED BOTTOM FLANGE DRILL DIM FROM 16109	HJR	10-18-05	VPK	050577
C	COOLER CLEAT LOC'N DIM WAS 2-3/4"; 19 U/M WAS EA.	RD	10/20/05	VPK	050577

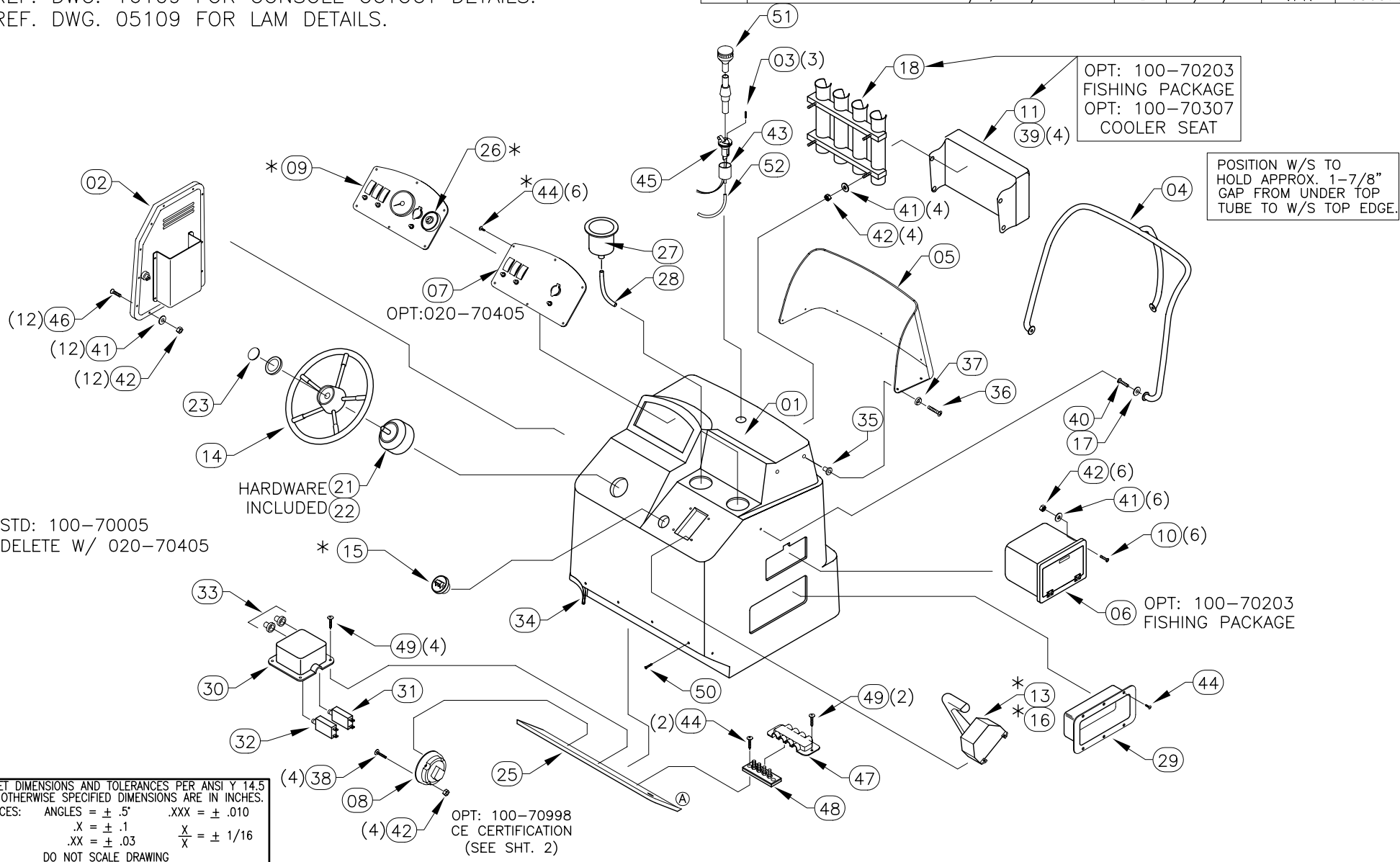

*STD: 100-70005
DELETE W/ 020-70405

INTERPRET DIMENSIONS AND TOLERANCES PER ANSI Y 14.5 UNLESS OTHERWISE SPECIFIED DIMENSIONS ARE IN INCHES.
TOLERANCES: ANGLES = ± .5° .XXX = ± .010
.X = ± .1 X = ± 1/16
.XX = ± .03
DO NOT SCALE DRAWING



CHECKED: R.AVILA	DATE: 10/04/05	DRAWN: M.ZAFFUTO	DATE: 10/04/05	SCALE: NONE	BOAT MODEL: 150MT06	MOLD NO.: 22J87100
APPD: K.RANIERI	DATE: 10/04/05	DWG. TITLE: CONSOLE SUB-ASSY.			INIT. REL. ECN NO.: 050577	DWG. NO.: 09201
DESIGN: V.KNIGHT	DATE: 10/04/05					SHT. NO.: 1 OF 3
INT. ENG: M.GATICA	DATE: 10/05/05					

THIS DOCUMENT IS THE PROPERTY OF BOSTON WHALER, INC. MFG. DEPT., EDGEWATER, FLORIDA. ALL RIGHTS ARE RESERVED. THIS DOCUMENT AND INFORMATION CONTAINED MUST NOT BE COPIED OR DISCLOSED TO OTHERS WITHOUT WRITTEN PERMISSION OF BOSTON WHALER, INC.

DWG. NO:
09201

REV.
C

CURRENT ECD
050577

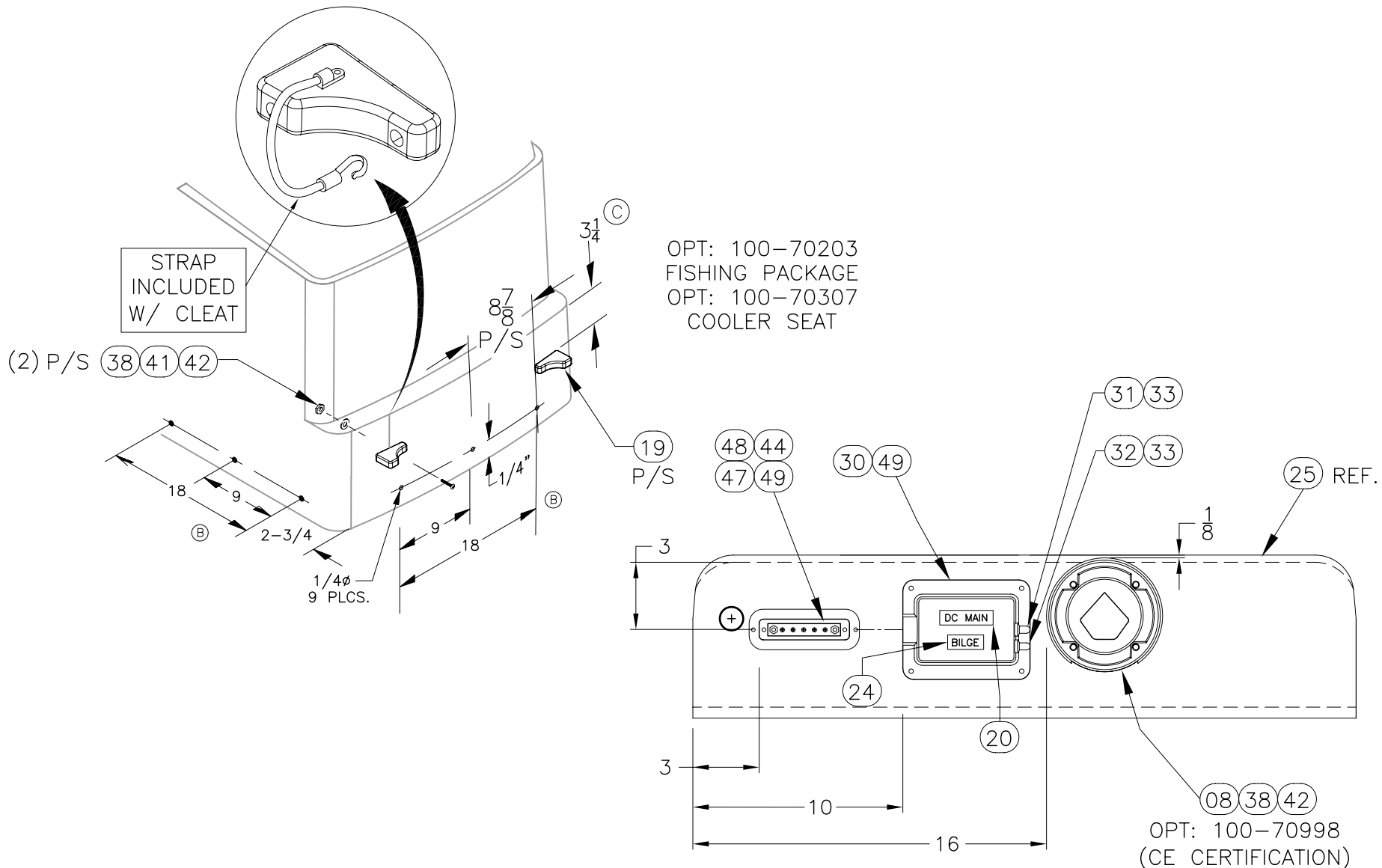

CONSOLE CLOSEOUT LAYOUT
(VIEW LOOKING AFT, FROM INSIDE CONSOLE)



INTERPRET DIMENSIONS AND TOLERANCES PER ANSI Y 14.5 UNLESS OTHERWISE SPECIFIED DIMENSIONS ARE IN INCHES.
TOLERANCES: ANGLES = ± .5° .XXX = ± .010
.X = ± .1 .XX = ± .03 X/X = ± 1/16
DO NOT SCALE DRAWING

DRAWN: M.ZAFFUTO DATE: 10/04/05 SCALE: NONE
DWG. TITLE: CONSOLE SUB-ASSY.

BOAT MODEL
150MT06

MOLD NO.
22J87100

INIT. REL. ECD NO:
050577

DWG. NO:
09201

SHT. NO.
2 OF 3

THIS DOCUMENT IS THE PROPERTY OF BOSTON WHALER, INC. MFG. DEPT.
EDGEWATER, FLORIDA. ALL RIGHTS ARE RESERVED. THIS DOCUMENT AND
INFORMATION CONTAINED MUST NOT BE COPIED OR DISCLOSED TO OTHERS
WITHOUT WRITTEN PERMISSION OF BOSTON WHALER, INC.

DWG. NO:
09201

REV.
C

CURRENT ECD
050577

BILL OF MATERIAL

ITEM	QTY.	U/M	DESCRIPTION	B.W.I. NO.
01	1	EA	FIBERGLASS PART, CONSOLE 160DA-99	22-J871-00
02	1	EA	DOOR, HDPE BW160DA/17MTK-06 CNSL	1803646
03	3	EA	SCREW, TAPPING #6 x 3/4" POH SC	1008564
04	1	EA	RAIL, GRAB BW170MT-02 CNSL SS	1689427
05	1	EA	W/S, BW170MT-02 CNSL CLEAR	1689418
06	1	EA	BOX, PLAS BW-04 TACKLE 2-DRWR WHT	1761591
07	1	EA	PANEL, BLANK:BW150MT-06 W/SWITCHES	1809846
08	1	EA	SWITCH, BATTERY ON/OFF W/O LOCK W/O DISC	0162701
09	1	EA	PANEL, BW150MT-06 SW	1809674
10	6	EA	SCREW, MACHINE #10-24 X 3/4" PTH SC	1008705
11	1	EA	CUSH, BW17MTK-05 CNSL ROD HLDR	1781379
(A) 12	1	EA	PANEL, HDPE BW170MT 02 CLSOUT CNSL BASE	1690180
13	1	EA	CONTROL, CNSL MNT SGL N/HARNESS GEN II	1752911
14	1	EA	STEERING WHEEL, 15" DIA SS 25DEG	1020197
15	1	EA	ACC PART, MERC SW (SAFETY ASSY)	0882605
16	4	EA	SCREW, TAPPING # 10 X 1" PTH SC	1008739
17	3	EA	WASHER, LOCK/SPLIT 5/16" SC	1260611
18	1	EA	ROD HOLDER, BW170MT-02 4-ROD ASSY	1690318
(C) 19	1	PR.	CLEAT ASSY, HDPE BW-06 COOLER 36QT	1812411
20	1	EA	LABEL, BW DC MAIN BREAKER	1075282
21	1	EA	STEERING, HELM NFB SGL	0626143
22	1	EA	STEERING BEZEL 90 DEG SGL	0626150
23	1	EA	EMBLEM, BW STEERING WHEEL CAP	1021054
24	1	EA	LABEL, BILGE (LEXAN)	1745123
25	1	EA	PANEL, HDPE BW140/160DA-99 CLSOUT CNSL LRG	1193093
26	1	EA	SWITCH, IGN ASSY 3-POSITION N/HOUSING	1806611
27	2	EA	DRINKHOLDR, PLAS W/DRAIN DEEP XLG SZ BLK	1727419
28	0	FT	HOSE, PVC CLEAR 3/8"	0124347
29	1	EA	BOX, ABS FIRE EXT SHORT WHT	1037555
30	1	EA	BOX, ABS HARNESS	1037530
31	1	EA	BRKR/SWITCH, PUSH BUTTON 30A ETA	0365775
32	1	EA	BRKR, MANUAL RESET 5A	0670497
33	2	EA	BOOT, RESET BRKR CLEAR	1066547
34	4	FT	TRIM, EDGE WHITE FLEX 'L'-TRIM	1020924
35	7	EA	NUT, WELL	1033422
36	7	EA	SCREW, MACHINE #10-32 x 1-1/4" PFH SC	1010107
37	7	EA	WASHER, FINISH #10 SS	0896258
38	8	EA	SCREW, MACHINE #10-24 X 1.25" POH SC	1008424
39	4	EA	SNAP STUD, W/#8 X 3/8" PH BR/NI/SS	0203786
40	3	EA	SCREW, CAP #5/16-18 X 1.25" HEX HD SC	1742748
41	26	EA	WASHER, FLAT #10 SC	1260751
42	30	EA	NUT, HEX NYLON LOCK #10-24 SC	1007772
43	1	EA	CAP, DRAINBOOT STERN LIGHT MAST BLK	1042761
44	14	EA	SCREW, TAPPING #8 x 5/8" PTH SC	1010925
45	1	EA	LIGHT, NAV STERN BASE RND CHR.	0331751
46	12	EA	SCREW, MACHINE #10-24 x 1.25" POH SC	1008424
47	1	EA	COVER, ABS BW MINIBUSS BLK	1185016
48	1	EA	BUSS BAR, MINIBUS BAR DC	1324334
49	6	EA	SCREW, TAPPING #8 x 1/2" PTH SC	1008812
50	6	EA	SCREW, TAPPING #8 x 3/4" PFH SC	1008408
51	1	EA	LIGHT, NAV A/R STERN 52" N/BEND	0574400
52	0	FT	TUBING, VINYL SPEEDO BLK	1043017

 <p>BOSTON WHALER PRODUCT DEV. & MFG. ENGINEERING GROUP</p>	<p>INTERPRET DIMENSIONS AND TOLERANCES PER ANSI Y 14.5 UNLESS OTHERWISE SPECIFIED DIMENSIONS ARE IN INCHES.</p> <p>TOLERANCES: ANGLES = ± .5° .XXX = ± .010 .X = ± .1 X = ± 1/16 .XX = ± .03 X = ±</p> <p>DO NOT SCALE DRAWING</p>	<p>DRAWN: M.ZAFFUTO</p> <p>DWG. TITLE: CONSOLE SUB-ASSY.</p>	<p>SCALE: NONE</p>	<p>BOAT MODEL 150MT06</p>	<p>MOLD NO. 22J87100</p>
	<p>DATE: 10/04/05</p>	<p>INIT. REL. ECN NO: 050577</p>	<p>DWG. NO.: 09201</p>	<p>SHT. NO. 3 of 3</p>	