

NOTES:

1. REFER TO DWG. 07-401, "WIRING DIAGRAM" FOR CONSOLE TO HULL CONNECTIONS.
2. ALL DRILLED HOLES (FOR MOUNTING COMPONENTS & HARDWARE TO HULL) SHALL BE SEALED W/ WHITE SILICONE SEALANT WHEN INSTALLED.
3. THE CANVAS MANUFACTURERS' INSTRUCTIONS (INCL. W/ CANVAS) SHALL BE USED WHEN OPTIONAL CANVAS IS INSTALLED.

REVISIONS					
REV.	DESCR.	BY	DATE	APPVD.	ECN NO.
A	#17 WAS QTY. 15; #27 ADDED.	RD	3/15/07	VPK	06093674
B	#19 WAS 1781378. ADDED SUN LOUNGE OPT. TO BOM. AND PG.2	JFH	5/02/07	VPK	06093674
C	#18 WAS 0958868	JFH	5/10/07	VPK	06093674
D	CHANGED P# FOR ITEM 1. 14, 24, TO 1897590, 1897589, 1898520, 1898519	TKJ	7/10/07	VPK	07074429

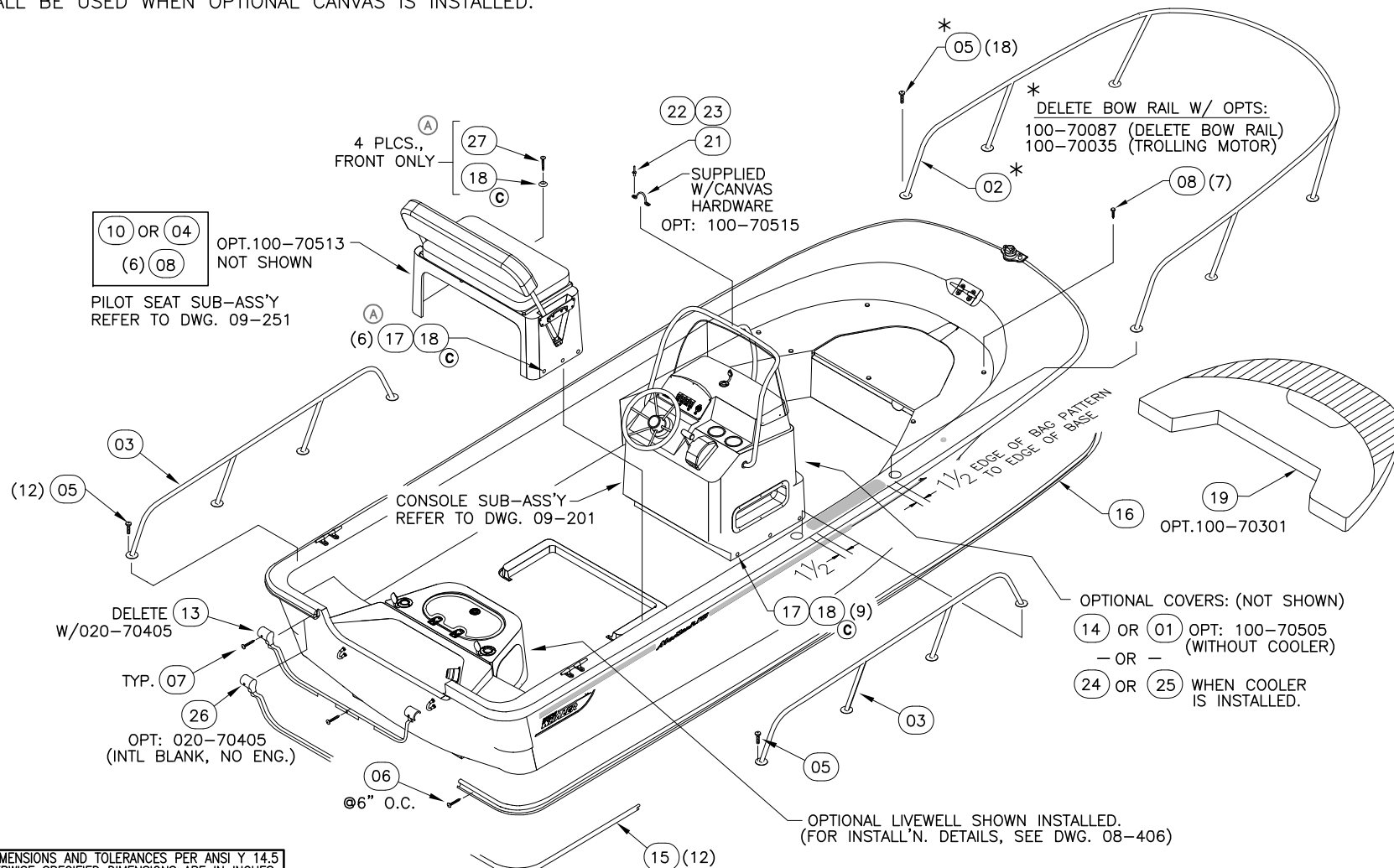

INTERPRET DIMENSIONS AND TOLERANCES PER ANSI Y 14.5 UNLESS OTHERWISE SPECIFIED DIMENSIONS ARE IN INCHES.
 TOLERANCES: ANGLES = ± .5° .XXX = ± .010
 .X = ± .1 X = ± 1/16
 .XX = ± .03 X = ± 1/16
 DO NOT SCALE DRAWING



CHECKED: R. AVILA	DATE: 2/14/07	DRAWN: R. DURHAM	DATE: 2/06/07	SCALE: NONE	BOAT MODEL	MOLD NO.
APPD: K. RANIERI	DATE: 2/14/07	DWG. TITLE:			170MT	
DESIGN: V. KNIGHT	DATE: 2/21/07	FINAL ASSEMBLY			INIT. REL. ECN NO:	DWG. NO:
INT. ENG: M. GATICA	DATE: 2/22/07				06093674	11201
					SHT. NO.	
					1	OF 3

THIS DOCUMENT IS THE PROPERTY OF BOSTON WHALER, INC. MFG. DEPT., EDGEWATER, FLORIDA. ALL RIGHTS ARE RESERVED. THIS DOCUMENT AND INFORMATION CONTAINED MUST NOT BE COPIED OR DISCLOSED TO OTHERS WITHOUT WRITTEN PERMISSION OF BOSTON WHALER, INC.

DWG. NO:
11201

REV.
D

CURRENT ECD
07074429

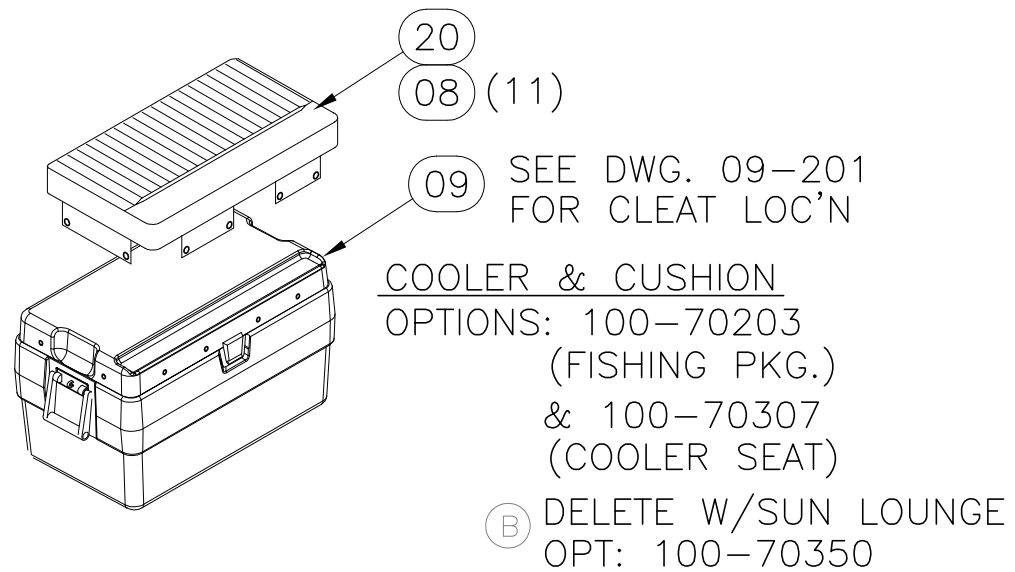
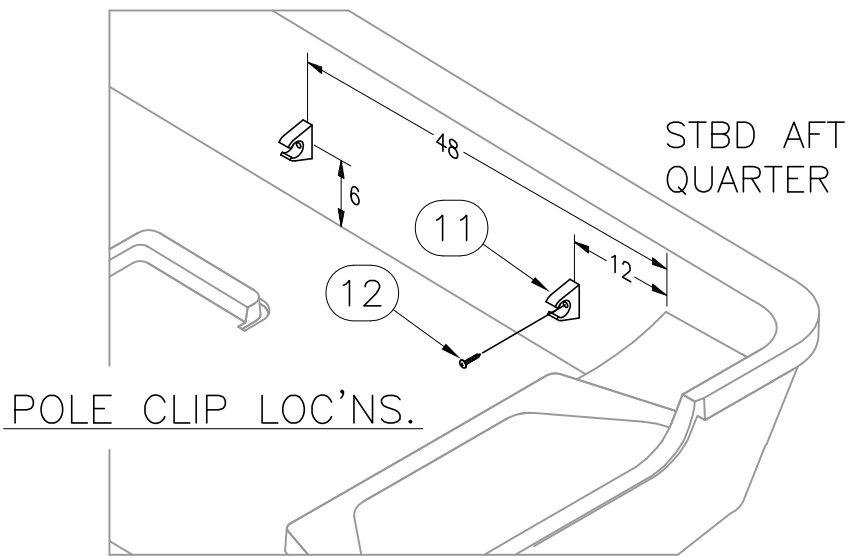

INTERPRET DIMENSIONS AND TOLERANCES PER ANSI Y 14.5 UNLESS OTHERWISE SPECIFIED DIMENSIONS ARE IN INCHES.
TOLERANCES: ANGLES = ± .5° .XXX = ± .010
.X = ± .1 .XX = ± .03 X/X = ± 1/16
DO NOT SCALE DRAWING

DRAWN: R.DURHAM DATE: 2/06/07 SCALE: NONE
DWG. TITLE: FINAL ASSEMBLY

BOAT MODEL 170MT	MOLD NO.
INIT. REL. ECN NO: 06093674	DWG. NO: 11201
SHT. NO. 2 OF 3	

PARTS LIST

ITEM	QTY.										U/M	DESCRIPTION	B.W.I. NO.	
	STD.	OPTIONAL												
(D) 1	-	-	-	-	-	-	-	-	-	1	-	EA.	CANVAS, BW170MT-08 CNSL CVR BLUE	1897590
2	1	-	-1	-1	-	-	-	-	-	-	-	EA.	RAIL, BOW BW170MT-06 SS	1817768
3	2	-	-	-	-	-	-	-	-	-	-	EA.	RAIL, SIDE BW170MT-02 AFT	1689429
4	-	-	-	-	-	-	-	-	-	1	-	EA.	CANVAS, BW170MT-05 REV'BL SEAT CVR BLUE	1771129
5	42	-	-18	-18	-	-	-	-	-	-	-	EA.	SCREW, MACHINE #1/4-20 X 1" PPH SC	1008580
6	90	-	-	-	-	-	-	-	-	-	-	EA.	SCREW, TAP #10A X 1.5" W/STP EPXY ORNG PFH	1814515
7	5	-	-	-	-	-	-	-	-	6	-	EA.	SCREW, TAPPING #8A X 1" PTH SC	1008804
(B) 8	-	-11	-	-	11	7	11	-	-	-	-	EA.	SNAP STUD, W/#8 X 3/8" PH BR/NI/SS	0203786
(B) 9	-	-1	-	-	1	1	-	-	-	-	-	EA.	COOLER, 72QT WHT	1016427
10	-	-	-	-	-	-	-	-	-	1	-	EA.	CANVAS, BW170MT-05 REV'BL SEAT CVR BLK	1771128
11	1	-	-	-	-	-	-	-	-	-	-	PR.	CLIP, POLE STRG BLK - MAST LIGHT	0590646
12	2	-	-	-	-	-	-	-	-	-	-	EA.	SCREW, TAPPING #10A X 1" PTH SC	1008739
13	1	-	-	-	-	-	-	-	-	-1	-	EA.	CAP, RUBRAIL BW170MT-03 TRNSM TRIM W/NOTCH	1743357
(D) 14	-	-	-	-	-	-	-	-	-	1	-	EA.	CANVAS, BW170MT-08 CNSL CVR BLK	1897589
15	1	-	-	-	-	-	-	-	-	-	-	EA.	INSERT, RUB RAIL CHAR FLEX 40'	1020817
16	1	-	-	-	-	-	-	-	-	-	-	EA.	RUBRAIL, PLASTIC CHAR 40'	1020858
(A) 17	15	-	-	-	-	-	-	-	-	-	-	EA.	SCREW, TAPPING #14A X 1.5" PFH SC	1008382
(C) 18	19	-	-	-	-	-	-	-	-	-	-	EA.	WASHER, FLANGE #14 SC	1305762
(B) 19	-	1	-	-	1	-	-	-	-	-	-	EA.	CUSH, BW170MT-08 BOW	1898228
(B) 20	-	-1	-	-	1	1	-	-	-	-	-	EA.	CUSH, BW17MTK-05 COOLER SEAT 72QT	1781380
21	-	-	-	-	-	-	-	-	-	2	-	EA.	RIVET, POP/BLIND #3/16 X 3/8" SS	0192120
22	-	-	-	-	-	-	-	-	-	1	-	EA.	CANVAS, BW17MTK-04 BIM TOP W/BOOT BLK	1753197
23	-	-	-	-	-	-	-	-	-	1	-	EA.	CANVAS, BW17MTK-04 BIM TOP W/BOOT BLUE	1756018
(D) 24	-	-	-	-	-	-	-	-	-	*	-	EA.	CANVAS, BW170MT-08 CNSL CVR W/COOLRCUTOUT BLU	1898520
(D) 25	-	-	-	-	-	-	-	-	-	*	-	EA.	CANVAS, BW170MT-08 CNSL CVR W/COOLRCUTOUT BLK	1898519
26	-	-	-	-	-	-	-	-	1	-	-	EA.	CAP, RUBRAIL BW170MT-02 TRNSM TRIM	1690126
(A) 27	4	-	-	-	-	-	-	-	-	-	-	EA.	SCREW, TAPPING #14A X 1" PFH SC	1008366

- (B) 100-70350
- 100-70035
- 100-70087
- 100-70203
- 100-70301
- 100-70307
- 100-70405
- 100-70505
- 100-70513
- 100-70515

WHEN CONSOLE CANVAS IS ORDERED,

- (A) #24 SUBSTITUTED FOR ITEM #1 WHEN COOLER INSTALLED.
- (B) #25 SUBSTITUTED FOR ITEM #14 WHEN COOLER INSTALLED.

** 700-00001, 700-00002



INTERPRET DIMENSIONS AND TOLERANCES PER ANSI Y 14.5 UNLESS OTHERWISE SPECIFIED DIMENSIONS ARE IN INCHES.
 TOLERANCES: ANGLES = ± .5° .XXX = ± .010
 .X = ± .1 X = ± 1/16
 .XX = ± .03

DO NOT SCALE DRAWING

DRAWN: R.DURHAM

DATE: 2/06/07

SCALE: NONE

BOAT MODEL

MOLD NO.

170MT

DWG. TITLE:

FINAL ASSEMBLY

INIT. REL. ECN NO:

DWG. NO:

SHT. NO.

06093674

11201

3 OF 3