

THIS DOCUMENT IS THE PROPERTY OF BOSTON WHALER, INC. MFG. DEPT., EDGEWATER, FLORIDA. ALL RIGHTS ARE RESERVED. THIS DOCUMENT AND INFORMATION CONTAINED MUST NOT BE COPIED OR DISCLOSED TO OTHERS WITHOUT WRITTEN PERMISSION OF BOSTON WHALER, INC.

DWG. NO: 08401 REV. D CURRENT ECD 060152

NOTES:

1. SEAL ALL FASTENINGS INTO HULL STRUCTURE USING WHITE SILICONE SEALANT AT TIME OF INSTALLATION.
2. USE HARDWARE SET & INSTRUCTIONS SUPPLIED W/TOP AT INSTALLATION.

REVISIONS					
REV.	DESCR.	BY	DATE	APPVD.	ECN NO.
A	CHANGED #04 FROM #10-24 X 1.25" PFH TO #10-24 X 1.75 POH	CSR	03/17/03	-	030329
B	2004 MODEL YEAR ENHANCEMENTS	RC	05/27/03	-	030352
C	CHANGED NUMBERING SYSTEM / APPLY ATT. BORDER	AVM	06/18/03	ZAC	030639
D	MODIFY DRAWING BORDER TO AN ATTRIBUTED BORDER	TS	02/06/06	AVM	060152

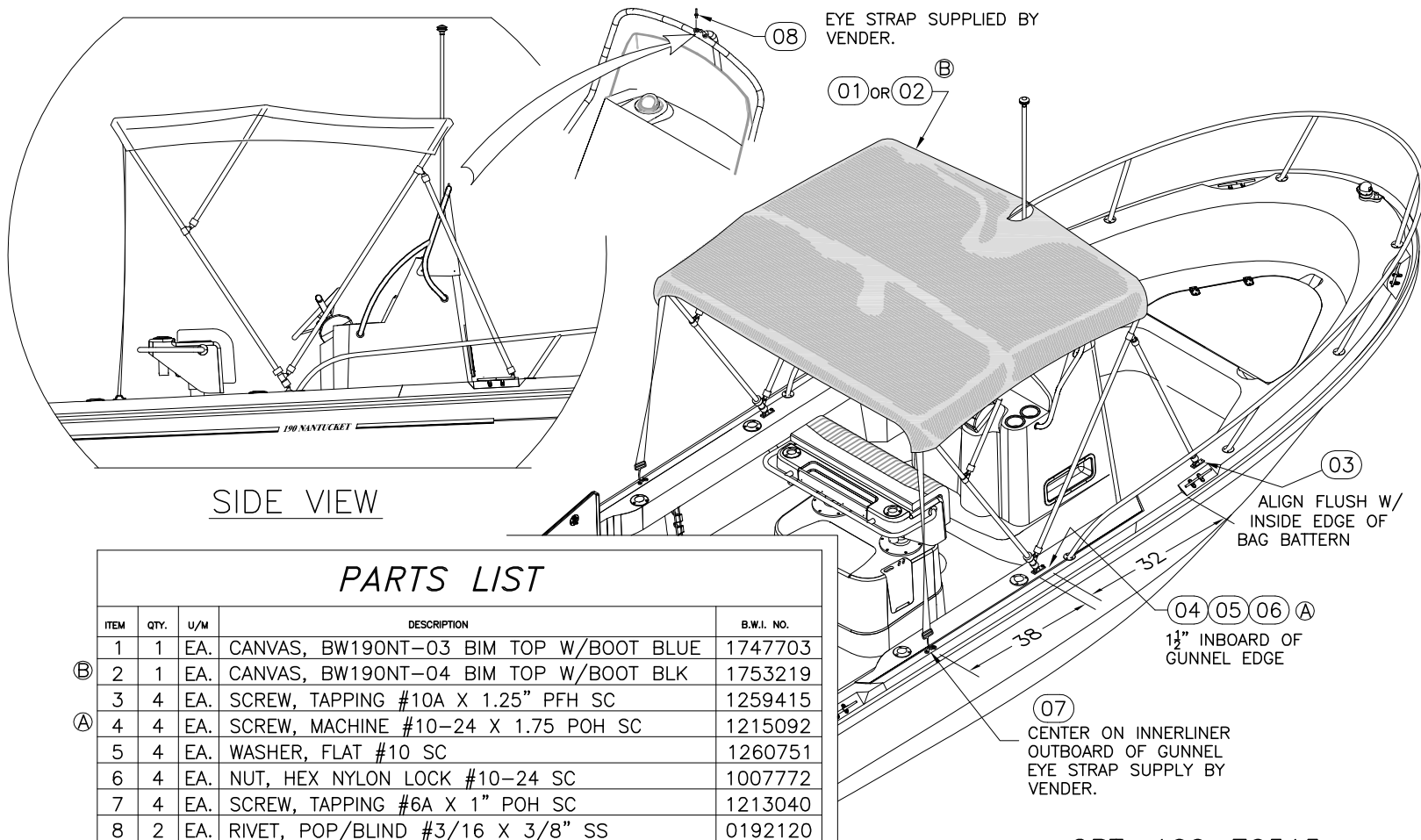

PARTS LIST

ITEM	QTY.	U/M	DESCRIPTION	B.W.I. NO.
1	1	EA.	CANVAS, BW190NT-03 BIM TOP W/BOOT BLUE	1747703
2	1	EA.	CANVAS, BW190NT-04 BIM TOP W/BOOT BLK	1753219
3	4	EA.	SCREW, TAPPING #10A X 1.25" PFH SC	1259415
4	4	EA.	SCREW, MACHINE #10-24 X 1.75 POH SC	1215092
5	4	EA.	WASHER, FLAT #10 SC	1260751
6	4	EA.	NUT, HEX NYLON LOCK #10-24 SC	1007772
7	4	EA.	SCREW, TAPPING #6A X 1" POH SC	1213040
8	2	EA.	RIVET, POP/BLIND #3/16 X 3/8" SS	0192120

OPT: 100-70515
SUN TOP W/BOOT

INTERPRET DIMENSIONS AND TOLERANCES PER ANSI Y 14.5 UNLESS OTHERWISE SPECIFIED DIMENSIONS ARE IN INCHES.
TOLERANCES: ANGLES = ± .5° .XXX = ± .010
.X = ± .1 .XX = ± .03 X = ± 1/16
DO NOT SCALE DRAWING



CHECKED: RA	DATE: 02/26/03	DRAWN: H READ	DATE: 02/13/03	SCALE: NONE	BOAT MODEL 1900R	MOLD NO.
APPD: KR	DATE: 02/26/03	DWG. TITLE: CANVAS INSTALLATION			INIT. REL. ECN NO: 021049	DWG. NO: 08401
DESIGN: L. SCHOLZ	DATE: 02/26/03					SHT. NO. 1 of 1
INT. ENG: M. GATICA	DATE: 02/28/03					